

Flute Fingering Chart

○ = open

● = pressed down

When more than one fingering is shown, the first is the most commonly used. The additional fingerings, known as **alternate fingerings**, are used in certain situations to allow for better technique.

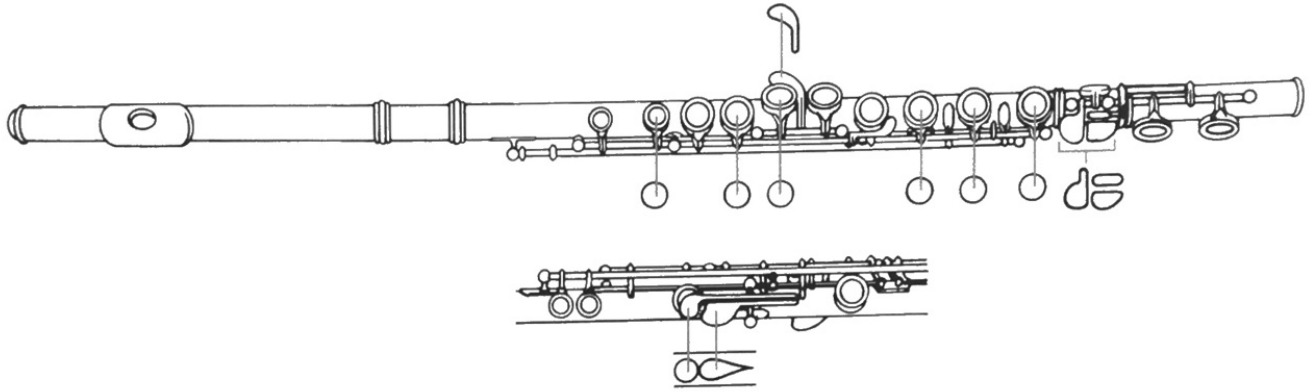

C	C# D \flat	D	D# E \flat	E F \flat	E# F

F# G \flat	G	G# A \flat	A	A# B \flat	B C \flat

B# C	C# D \flat	D	D# E \flat	E F \flat	E# F

F# G \flat	G	G# A \flat	A	A# B \flat	B C \flat

B# C	C# D \flat	D	D# E \flat	E F \flat	E# F

B \flat Clarinet Fingering Chart

- = open
- = pressed down

When more than one fingering is shown, the first is the most commonly used. The additional fingerings, known as **alternate fingerings**, are used in certain situations to allow for better technique.

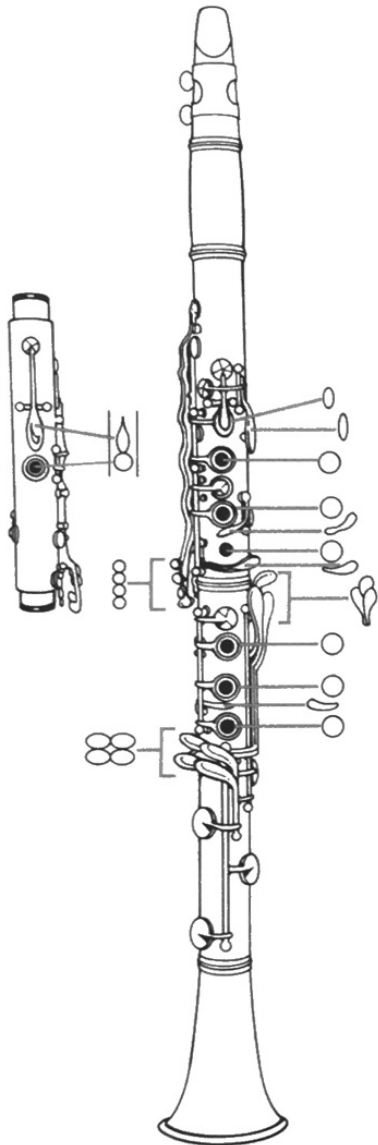

E F \flat	E \sharp F	F \sharp G \flat	G	G \sharp A \flat

A	A \sharp B \flat	B C \flat	B \sharp C	C \sharp D \flat	D	D \sharp E \flat

E F \flat	E \sharp F	F \sharp G \flat	G	G \sharp A \flat	A

A \sharp B \flat	B C \flat	B \sharp C	C \sharp D \flat	D	D \sharp E \flat	E F \flat	E \sharp F

F \sharp G \flat	G	G \sharp A \flat	A	A \sharp B \flat	B C \flat	B \sharp C	C \sharp D \flat	D

B \flat Bass Clarinet Fingering Chart

- = open
- = pressed down

When more than one fingering is shown, the first is the most common used. The additional fingerings, known as **alternate fingerings**, are used in certain situations to allow for better technique.

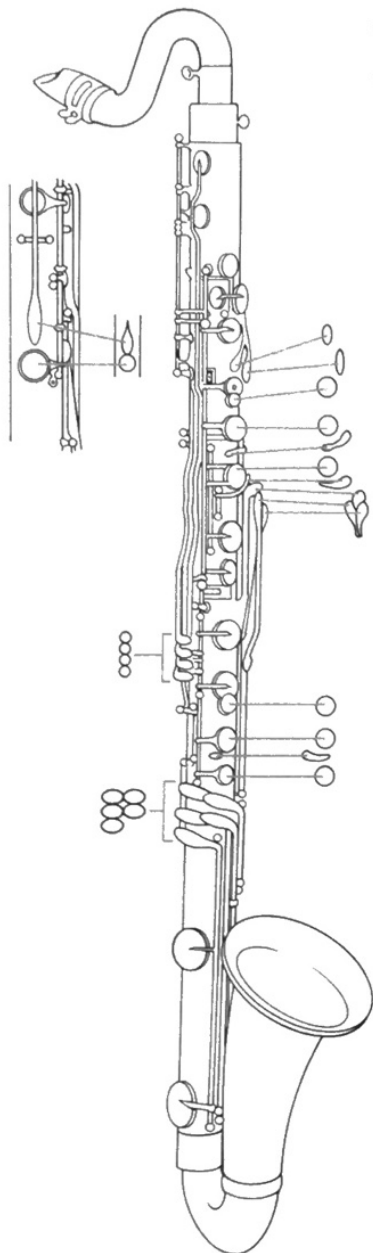

D \sharp E \flat	E F \flat	E \sharp F	F \sharp G \flat	G	G \sharp A \flat

A	A \sharp B \flat	B C \flat	B \sharp C	C \sharp D \flat	D	D \sharp E \flat

E F \flat	E \sharp F	F \sharp G \flat	G	G \sharp A \flat	A

A \sharp B \flat	B C \flat	B \sharp C	C \sharp D \flat	D	D \sharp E \flat	E F \flat	E \sharp F

F \sharp G \flat	G	G \sharp A \flat	A	A \sharp B \flat	B C \flat	B \sharp C

E♭ Alto Saxophone Fingering Chart

- = open
- = pressed down

When more than one fingering is shown, the first is the most commonly used. The additional fingerings, known as **alternate fingerings**, are used in certain situations to allow for better technique.

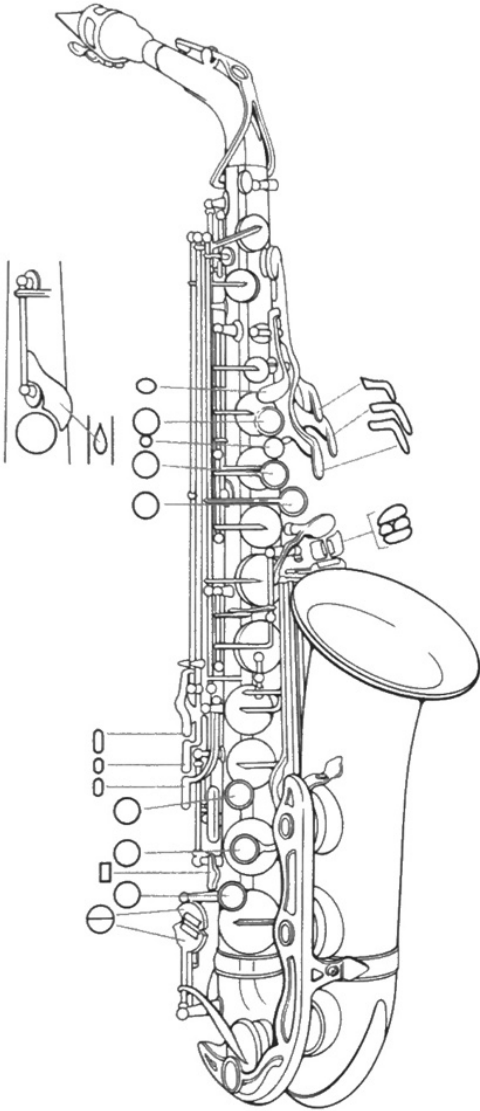

A♯ B♭	B C♭	B♯ C	C♯ D♭	D	D♯ E♭

E F♭	E♯ F	F♯ G♭	G	G♯ A♭	A

A♯ B♭	B C♭	B♯ C	C♯ D♭	D	D♯ E♭

E F♭	E♯ F	F♯ G♭	G	G♯ A♭	A	A♯ B♭

B C♭	B♯ C	C♯ D♭	D	D♯ E♭	E F♭	E♯ F

B \flat Tenor Saxophone Fingering Chart

- = open
- = pressed down

When more than one fingering is shown, the first is the most commonly used. The additional fingerings, known as **alternate fingerings**, are used in certain situations to allow for better technique.

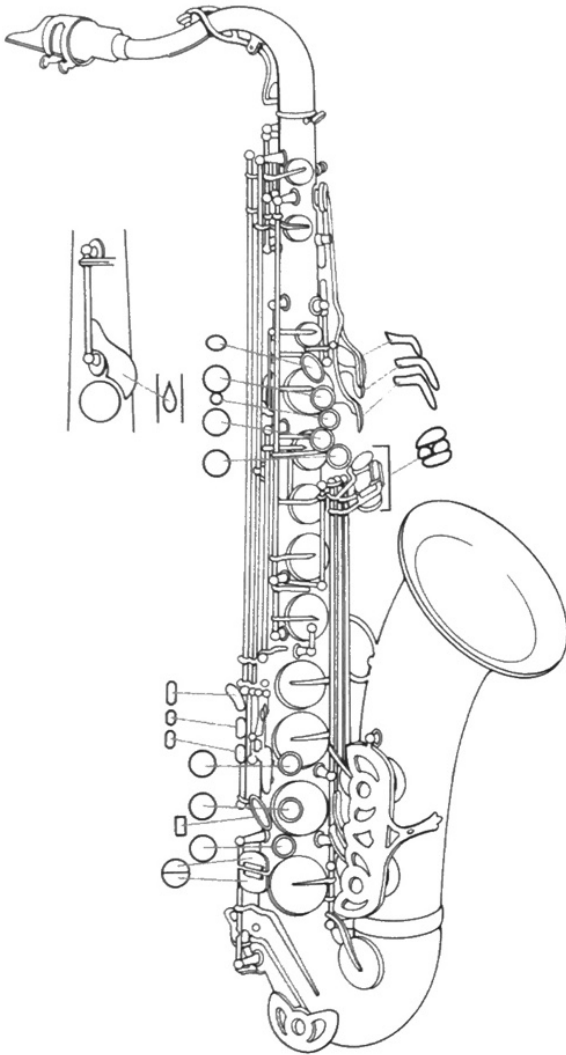

A \sharp B \flat	B C \flat	B \sharp C	C \sharp D \flat	D	D \sharp E \flat

E F \flat	E \sharp F	F \sharp G \flat	G	G \sharp A \flat	A

A \sharp B \flat	B C \flat	B \sharp C	C \sharp D \flat	D	D \sharp E \flat

E F \flat	E \sharp F	F \sharp G \flat	G	G \sharp A \flat	A	A \sharp B \flat

B C \flat	B \sharp C	C \sharp D \flat	D	D \sharp E \flat	E F \flat	E \sharp F

B \flat Trumpet/Cornet Fingering Chart

The numbers indicate which valve should be pressed down.

0 = no valves pressed down

B \flat Trumpet

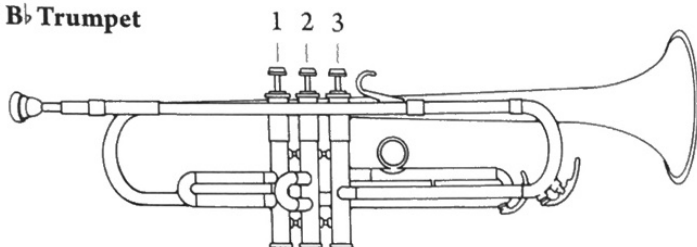

B \flat Cornet

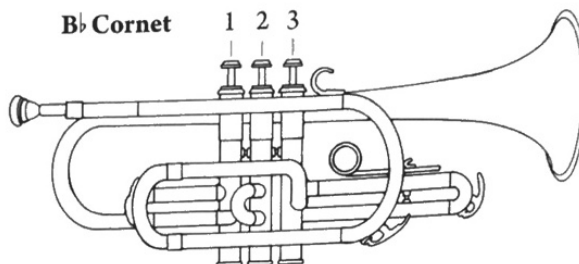

F \sharp G \flat	G	G \sharp A \flat	A	A \sharp B \flat
1 2 3	1 3	2 3	1 2	1

B C \flat	B \sharp C	C \sharp D \flat	D	D \sharp E \flat
2	0	1 2 3	1 3	2 3

E F \flat	E \sharp F	F \sharp G \flat	G	G \sharp A \flat
1 2	1	2	0	2 3

A	A \sharp B \flat	B C \flat	B \sharp C	C \sharp D \flat
1 2	1	2	0	1 2

D	D \sharp E \flat	E F \flat	E \sharp F	F \sharp G \flat	G
1	2	0	1	2	0

Trombone Position Chart

The number indicates what position to use.

- = a shortened slide position.

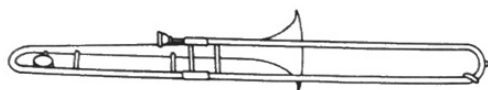

1

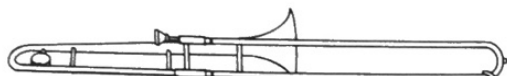

2



3



4

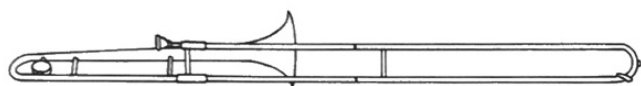

5

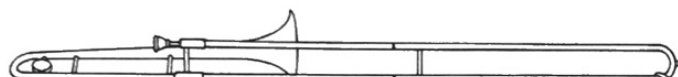

6

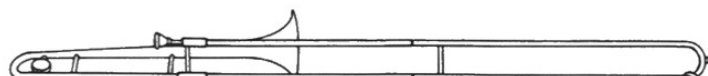

7

E F \flat	F	F \sharp G \flat	G
7	6	5	4

G \sharp A \flat	A	A \sharp B \flat	B C \flat
3	2	1	7

B \sharp C	C \sharp D \flat	D	D \sharp E \flat
6	5	4	3

E F \flat	E \sharp F	F \sharp G \flat	G	G \sharp A \flat	A	A \sharp B \flat
2	1 or 6	5	4	3	2 or 6	1

B C \flat	B \sharp C	C \sharp D \flat	D	D \sharp E \flat	E F \flat	E \sharp F
4	3	2	1 or -4	3	2	1

Baritone/Euphonium B.C. Fingering Chart

The numbers indicate which valves should be pressed down.

0 = no valves pressed down

Baritone

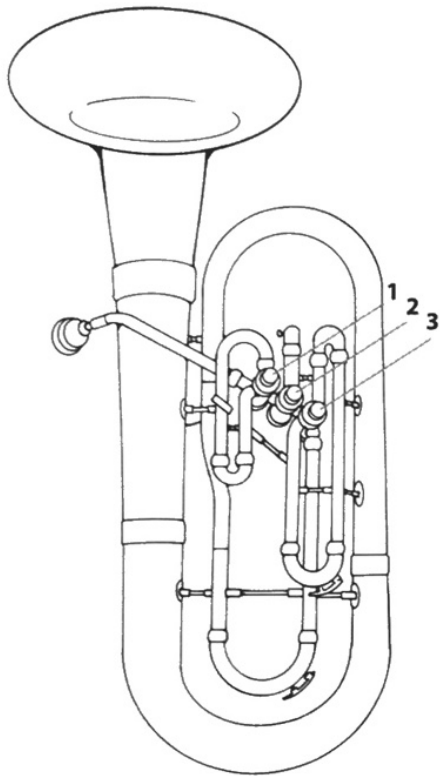

E F \flat	F	F \sharp G \flat	G
1 2 3	1 3	2 3	1 2

G \sharp A \flat	A	A \sharp B \flat	B C \flat
1	2	0	1 2 3

B \sharp C	C \sharp D \flat	D	D \sharp E \flat
1 3	2 3	1 2	1

Euphonium

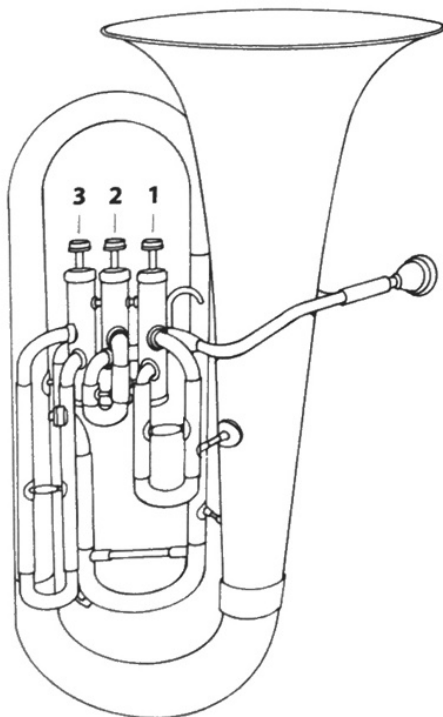

E F \flat	E \sharp F	F \sharp G \flat	G
2	0	2 3	1 2

G \sharp A \flat	A	A \sharp B \flat	B C \flat	B \sharp C
1	2	0	1 2	1

C \sharp D \flat	D	D \sharp E \flat	E F \flat	E \sharp F
2	0	1	2	0

BB \flat TUBA FINGERING CHART

E F \flat	E \sharp F	F \sharp G \flat	G	G \sharp A \flat
1 2 3	1 3	2 3	1 2	1

A	A \sharp B \flat	B C \flat	B \sharp C	C \sharp D \flat
2	0	1 2 3	1 3	2 3

D	D \sharp E \flat	E F \flat	E \sharp F	F \sharp G \flat
1 2	1	2	0	2 3

G	G \sharp A \flat	A	A \sharp B \flat	B C \flat
1 2	1	2	0	1 2

B \sharp C	C \sharp D \flat	D	D \sharp E \flat	E F \flat
1	2	0	1	2

E \sharp F	F \sharp G \flat	G	G \sharp A \flat	A	A \sharp B \flat
0	2 3	1 2	1	2	0

Mallet Percussion Keyboard Layout/Note Chart

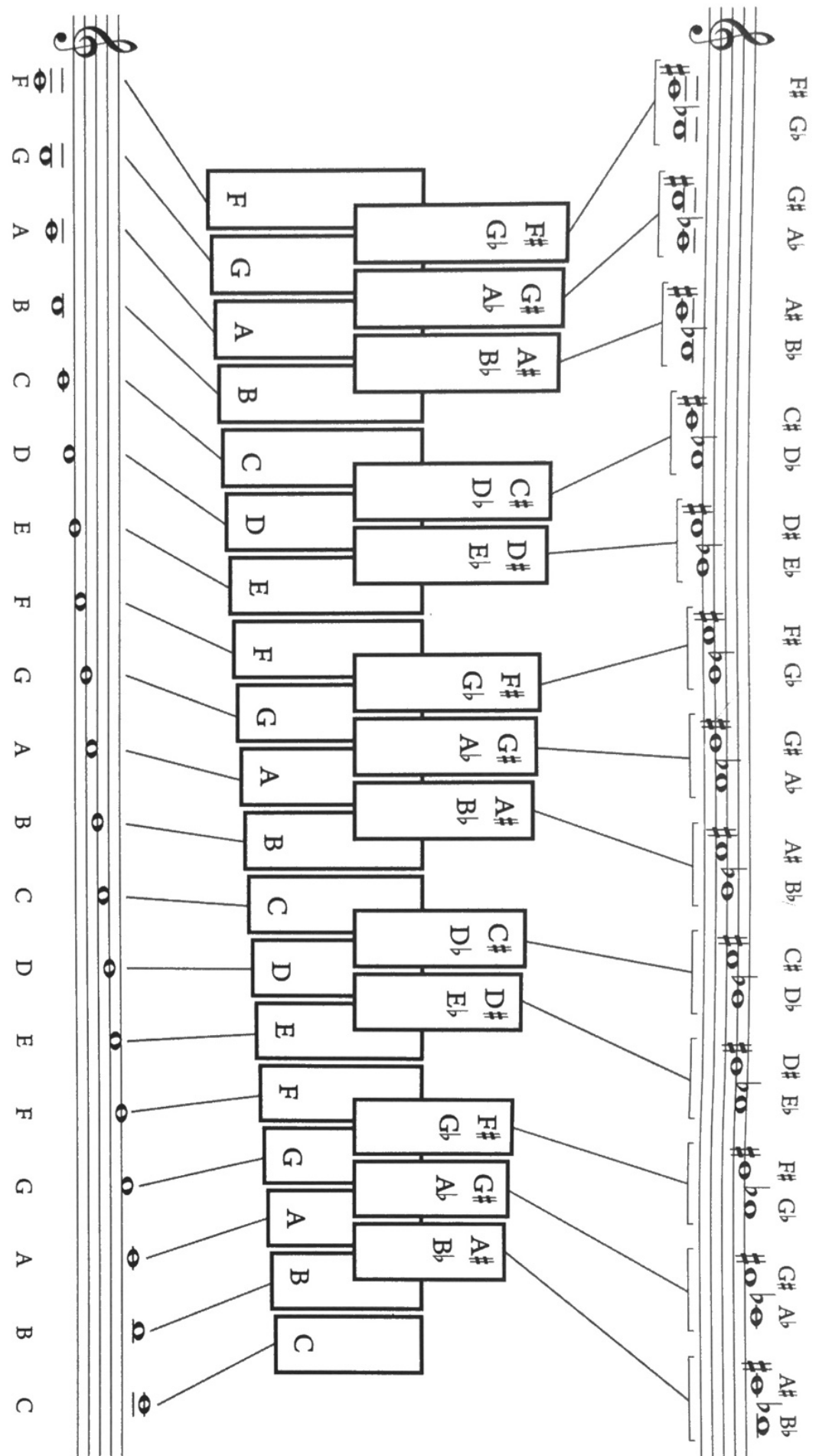

©2010 Kjos Music Press